

SPECIFICATIONS

GENERAL:

The surface drainage system shall be Food Safe Area Drain - Square Top, complete with strainer basket, as manufactured by FoodSafe Drains.

MATERIALS:

T304 Stainless Steel or T316 Stainless Steel

LOAD CLASS:

Load Class E

INSTALLATION:

The Food Safe Area Drain - Square Top shall be installed in accordance with the manufacturer's installation instructions and recommendations.

TYPICAL PROFILE OF A FOOD SAFE AREA DRAIN - SQUARE TOP SYSTEM

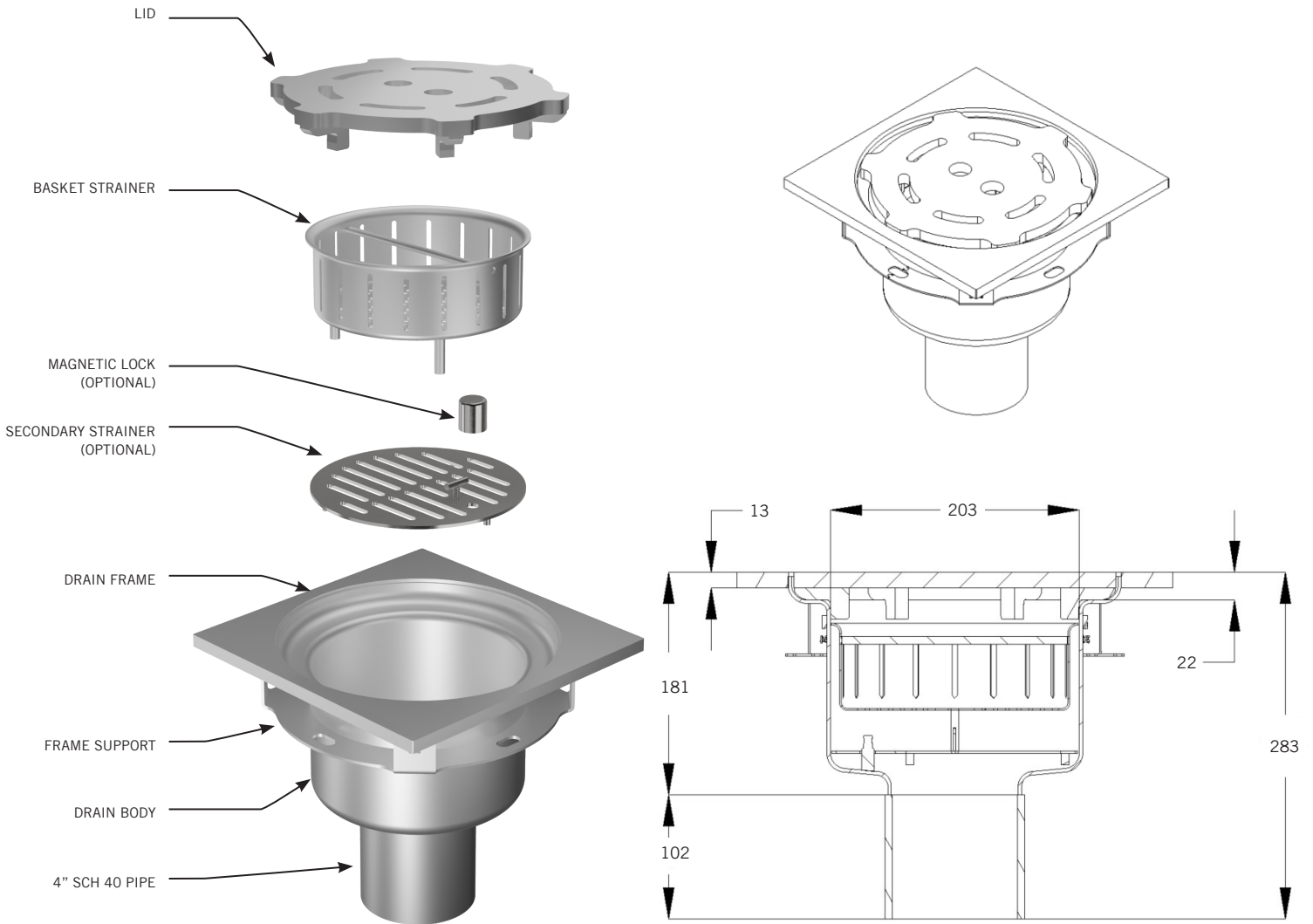

MEASUREMENTS

DESCRIPTION	DRAIN TOP ID MM	DRAIN OD MM	LID DIAMETER MM	LID HEIGHT MM	OUTLET DIAMETER MM	OUTER EDGE MM
FSD AREA - SQUARE	203	267	248	13	76 or 102	356

OPTIONALLY, NON-MAGLOCK DESIGN ALSO AVAILABLE.
SPECIFYING ENGINEER IS RESPONSIBLE FOR CONCRETE ENCASEMENT AND REINFORCING BASED UPON APPLICATION AND LOCAL CODES.
SLOT DRAIN SYSTEMS RESERVES THE RIGHT TO CHANGE THE PRODUCT AND SPECIFICATIONS WITHOUT NOTICE